



LNP-C500G Series

Compact 5-Port Industrial Gigabit PoE+ Unmanaged Ethernet Switch, w/4*10/100/1000Tx (PSE: 30W/Port) + 1*10/100/1000Tx



Version 1.0
(October 2017)

User Manual



© Copyright 2017 Antaira Technologies, LLC.

All Rights Reserved

This document contains information which is protected by copyright. Reproduction, adaptation or translation without prior permission is prohibited, except as allowed under the copyright laws.

Trademark Information

Antaira is a registered trademark of Antaira Technologies, LLC. Microsoft Windows and the Windows logo are the trademarks of Microsoft Corp. All other brand and product names are trademarks or registered trademarks of their respective owners.

Disclaimer

Antaira Technologies, LLC. provides this manual without warranty of any kind, expressed or implied, including but not limited to the implied warranties of merchantability and fitness for a particular purpose. Antaira Technologies, LLC. may make improvements and/or changes to the product and/or specifications of the product described in this manual, without prior notice. Antaira Technologies, LLC. will not be liable for any technical inaccuracies or typographical errors found in this guide. Changes are periodically made to the information contained herein and will be incorporated into later versions of the manual. The information contained is subject to change without prior notice.

FCC Notice

This equipment has been tested and found to comply with the limits for a Class-A digital device, pursuant to Part 15 of the FCC rules. These limits are designed to provide reasonable protection against harmful interference in a residential installation. This equipment generates, uses, and can radiate radio frequency energy. It may cause harmful interference to radio communications if the equipment is not installed and used in accordance with the instructions. However, there is no guarantee that interference will not occur in a particular installation. If this equipment does cause harmful interference to radio or television reception, which can be determined by turning the equipment off and on, the user is encouraged to try to correct the interference by one or more of the following measures:

- Reorient or relocate the receiving antenna.
- Increase the separation between the equipment and receiver.
- Connect the equipment into an outlet on a circuit different from that to which the receiver is connected.
- Consult the dealer or an experienced radio/TV technician for help.

Caution: Any changes or modifications not expressly approved by the grantee of this device could void the user's authority to operate the equipment.

CE Mark Warning

This is a Class-A product. In a domestic environment, this product may cause radio interference in which case the user may be required to take adequate measures.

Industrial Ethernet Switch

User Manual

This manual supports the following models:

- LNP-C500G
- LNP-C500G-T

Please check our website (www.antaira.com) for any updated manual or contact us by e-mail (support@antaira.com).

Table of Contents

1. Overview	1
1.1 Key Features.....	1
1.2 Package Contents.....	1
1.3 Safety Precaution	1
2. Hardware Description	2
2.1 Physical Dimensions	2
2.2 Front Panel	3
2.3 Top View	3
2.4 LED Indicators	4
2.5 Ethernet Ports	4
2.6 Cabling	5
2.7 Wiring the Power Inputs.....	5
3. Mounting Installation	7
3.1 DIN-Rail Mounting.....	7
3.2 Wall Mounting	9
4. Hardware Installation.....	10
4.1 Installation Steps.....	10
5. Network Application	11
6. Trouble Shooting	12
7. Technical Specifications	13

1. Overview

Antaira Technologies' **LNP-C500G series** is a compact 5-port industrial gigabit PoE+ unmanaged Ethernet switch. The small form factor of this metal IP30 rated design is 50% smaller which allows for a more versatile implementation. The LNP-C500G series is equipped with 4*10/100/1000Tx Ethernet ports that support IEEE 802.3af/at for a maximum of 30W/port and 1*10/100/1000Tx Ethernet port. The LNP-C500G series can handle high bandwidth applications in tight spaces. The LNP-C500G series supports high EFT & ESD protection through the redundant power inputs that support reverse polarity and overload current protection. This product series supports DIN-rail as well as wall mountable orientations and provides operating temperature range models in STD: -10°C to 70°C and EOT: -40°C to 75°C. This is an industrial grade unit applicable for networking applications in factory automation, ITS, power/utility, water wastewater treatment plants, or any application that needs a compact solution.

1.1 Key Features

- System Interface/Performance
 - RJ-45 ports support the auto MDI function
 - Embedded 4*10/100/1000Tx (PSE 30W/port) and 1*100/1000Tx port
 - Store-and-forward switching architecture
- Power Input
 - DC 48~55V redundant power with a 4-pin removal terminal block
- Operating Temperature
 - Standard operating temperature model: -10°C ~ 70°C
 - Extended operating temperature model (-T): -40°C ~ 75°C
- Case/Installation
 - IP30 protection
 - DIN-Rail and wall mount design

1.2 Package Contents

- 1 - Quick Installation Guide
- 1 - LNP-C500G Industrial PoE+ Gigabit Unmanaged Ethernet Switch
- 1 - Wall mounting bracket set with screws
- 1 - DC cable - 18 AWG & DC jack 5.5x2.1mm

1.3 Safety Precaution

Attention: If the DC voltage is supplied by an external circuit, please use a protection device on the power supply input. The industrial Ethernet switch's hardware specs, ports, cabling information, and wiring installation will be described within this user manual.

2. Hardware Description

2.1 Physical Dimensions

Figure 2.1, below, shows the physical dimensions of Antaira Technologies' LNP-C500G series:

(W x H x D) is **30mm x 95mm x 75mm**

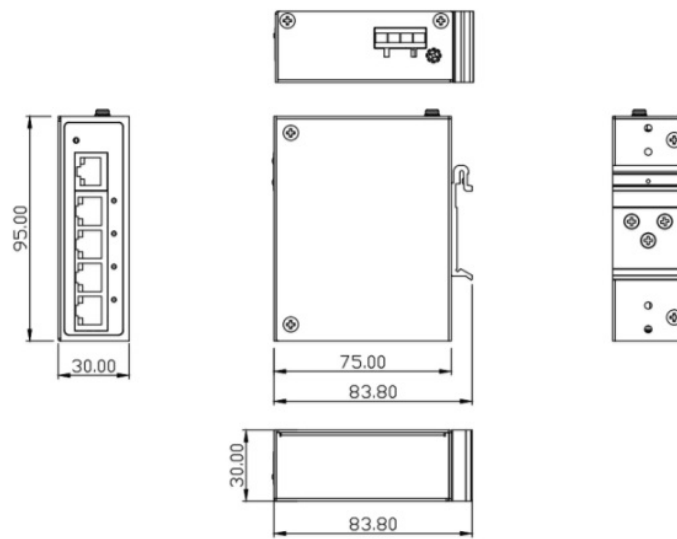

Figure 2.1
Physical Dimensions

2.2 Front Panel

The front panel of the LNP-C500G series can be seen below (Figure 2.2).

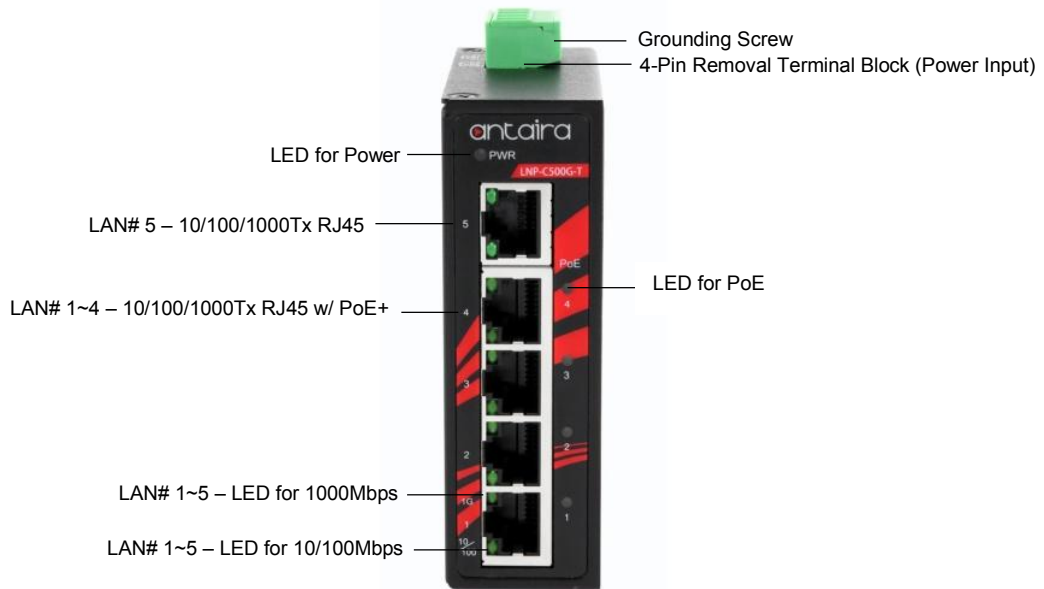

Figure 2.2
Front Panel

2.3 Top View

Figure 2.3, below, shows the top panel of the LNP-C500G series that is equipped with one 4-pin removal terminal block connector for dual DC power inputs (48~55VDC).

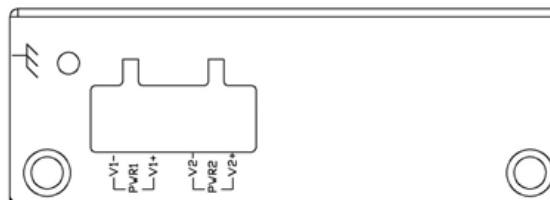

Figure 2.3
Top Panel View

2.4 LED Indicators

There are LED light indicators located on the front panel that displays the power and network status. Each LED indicator has a different color and has its own specific meaning, see below in *Table 2.1*.



LED	Color	Description	
Power	Green	On	Power input 1 or 2 is active
		Off	Power input 1 and 2 are inactive
PoE 1-4	Green	On	The port is supplying power to the powered-device
		Off	No powered-device attached or power supply fails
LAN Port 1 ~ 5	 Green	On	Connected to network, 1000Mbps
		Flashing	Networking is active
		Off	Not connected to network
	 Green	On	Connected to network, 10/100Mbps
		Flashing	Networking is active
		Off	Not connected to network

Table 2.1

LED Indicators

2.5 Ethernet Ports

■ RJ-45 Ports

RJ-45 Ports (Auto MDI/MDIX): The RJ-45 port is auto-sensing for 10/100Base-Tx or 1000Base-Tx device connections. Auto MDI/MDIX means that the switch can connect to another switch or workstation without changing the straight-through or crossover cabling. See the figures shown below for the straight-through and crossover cabling schematics.

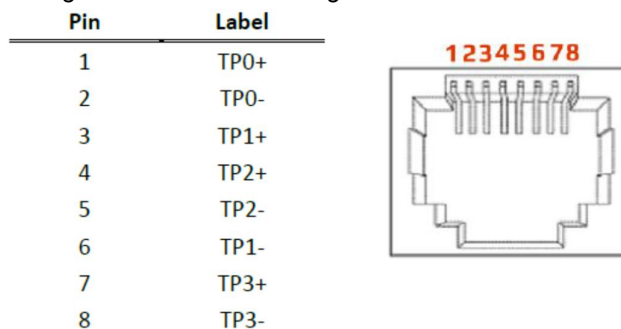

Figure 2.4: RJ-45 Ethernet Port Pin

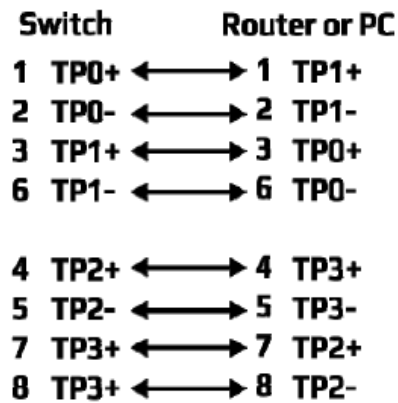

Figure 2.5
Straight-Through Cables Schematic

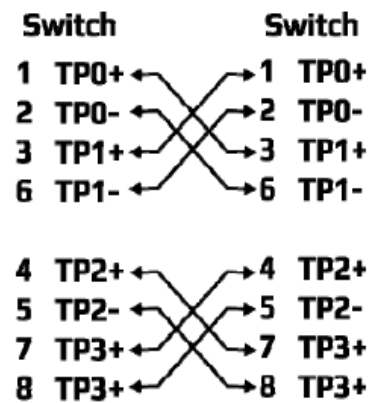

Figure 2.6
Crossover Cables Schematic

2.6 Cabling

- Twisted-pair segments can be connected with an Unshielded Twisted Pair (UTP) or Shielded Twisted Pair (STP) cable. The cable between the equipment and the link partner (media converter, switch, hub, workstation, etc.) must be less than 100 meters (328 ft.) long.

2.7 Wiring the Power Inputs

Please follow the steps below to insert the power wire.

- Insert the positive and negative wires into the PWR1 (V1+, V1-) and PWR2 (V2+, V2-) contacts on the terminal block connector as shown below in *Figure 2.7*.

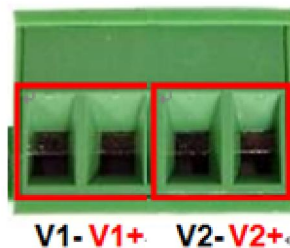

Figure 2.7
Power Terminal Block

2. Tighten the wire-clamp screws to prevent the wires from loosening, as shown below in *Figure 2.8*.



Figure 2.8
Power Terminal Block

-
- **Note:**
- Only use copper conductors, **60/75° C**, tighten to **5 lbs.**
 - The wire gauge for the terminal block should range between **18~20 AWG.**
-

3. Mounting Installation

3.1 DIN-Rail Mounting

The DIN-Rail is pre-installed on the industrial Ethernet switch from the factory. If the DIN-Rail is not on the switch, please refer to *Figure 3.1* to learn how to install the DIN-Rail on the switch.

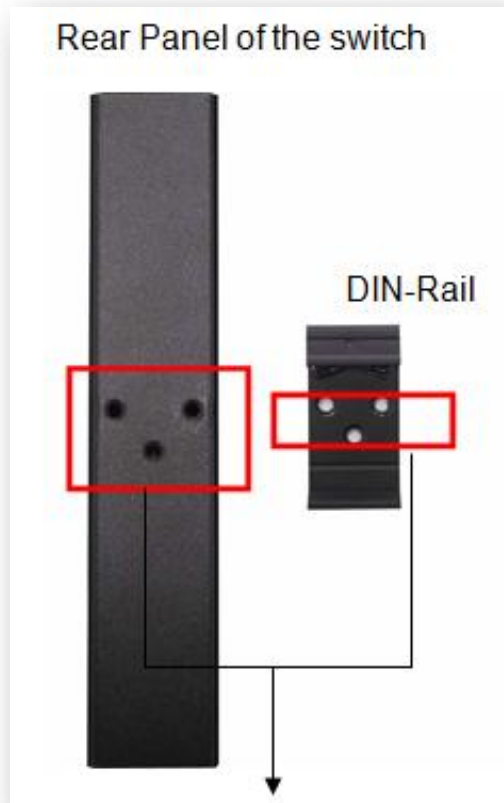

Figure 3.1

The Rear Side of the Media Converter and DIN-Rail Bracket

Follow the steps below to learn how to hang the industrial Ethernet switch.

1. Use the screws to install the DIN-Rail bracket on the rear side of the industrial Ethernet switch.
2. To remove the DIN-Rail bracket, do the opposite from step 1.
3. After the DIN-Rail bracket is installed on the rear side of the switch, insert the top of the DIN-Rail on to the track as shown below in *Figure 3.2*.



Figure 3.2
Insert on the DIN-Rail

4. Lightly pull down the bracket on to the rail as shown below in *Figure 3.3*.

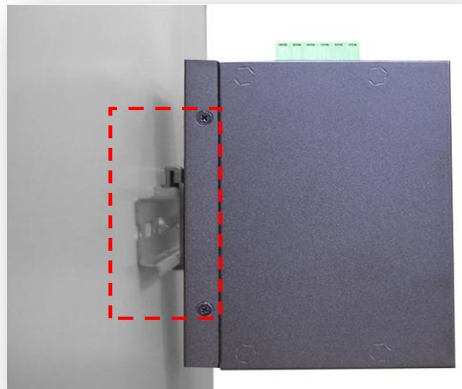

Figure 3.3
Secure on to the DIN-Rail

5. Check if the bracket is mounted tightly on the rail.
6. To remove the industrial Ethernet switch from the rail, do the opposite from the above steps.

4. Hardware Installation

4.1 Installation Steps

This section will explain how to install Antaira Technologies' LNP-C500G series.

Installation Steps

1. Unpack the switch from the original packing box.
2. Check if the DIN-Rail bracket is screwed on the switch.
 - a. If the DIN-Rail is not screwed on the switch, please refer to the **DIN-Rail Mounting** section for DIN-Rail installation.
 - b. For wall mounting, please refer to the **Wall Mounting** section for wall mounting installation.
3. For DIN-Rail or wall mounting, please refer to the **Mounting Installation** section.
4. Power on the switch and then the power LED light will turn on.
 - a. For wiring power, please refer to the **Wiring the Power Inputs** section.
 - b. Please refer to the **LED Indicators** section for LED light indication.
5. Prepare the twisted-pair, straight-through category 5 cable for Ethernet connection.
6. Insert one side of the RJ-45 cable into the switch's Ethernet port and on the other side into the networking device's Ethernet port, e.g. switch PC or server. The Ethernet port's (RJ-45) LED on the switch will turn on when the cable is connected to the networking device.
 - a. Please refer to the **LED Indicators** section for LED light indication information.
7. When all connections are set and the LED lights all show normal, the installation process is complete.

5. Network Application

This segment provides an example of an industrial Ethernet switch application (Figure 5.1).

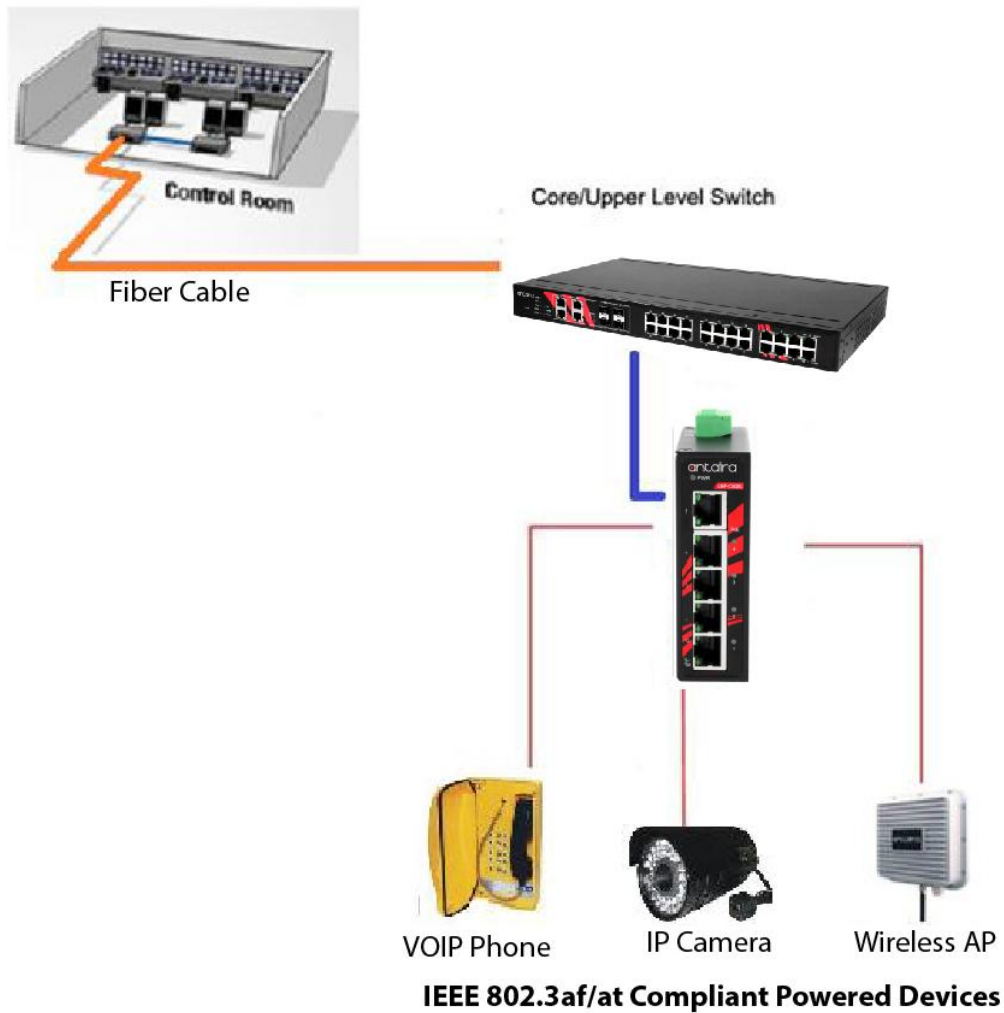

Figure 5.1
Application Example

6. Trouble Shooting

- Always verify the right power cord or adapter is being used. Never use a power supply or adapter with a non-compliant DC output voltage or it will burn the equipment.
- Select the proper UTP or STP cable in order to construct the network. Use an Unshielded Twisted-Pair (UTP) or Shield Twisted-Pair (STP) cable for RJ-45 connections: 100Ω Category 5e for 10/100/1000Mbps. Also be sure that the length of any twisted-pair connection does not exceed 100 meters (328 feet).
- **Diagnosing LED Indicators:** To assist in identifying problems, the switch can be easily monitored with the LED indicators which help to identify if any problems exist.
 - Please refer to the LED Indicators section for LED light indication information.
- If the power indicator LED does not turn on when the power cord is plugged in, the user may have a problem with the power cord. Check for loose power connections, power losses, or surges at the power outlet.
 - Please contact Antaira for technical support if the problem cannot be resolved.
- If the switch LED indicators are normal and the connected cables are correct but the packets still cannot transmit, please check the system's Ethernet devices' configuration, or status.

7. Technical Specifications

Table 7.1 has the technical specifications

Standards	IEEE 802.3	10Base-T 10Mbit/s Ethernet
	IEEE 802.3u	100Base-TX, Fast Ethernet
	IEEE 802.3ab	1000Base-TX Gigabit Ethernet
	IEEE 802.3af	Power-over-Ethernet
	IEEE 802.3at	Power-over-Ethernet Plus (Enhanced)
Technology	Protocol	CSMA/CD
	Data Process	Store-and-Forward
	Transfer Rate	14,880pps for 10Base-T Ethernet port 148,800pps for 100Base-TX Fast Ethernet port 1,4888,000pps for Gigabit Ethernet port
	Transmission Distance	Up to 100m (Ethernet)
	Transmission Speed	Up to 1000Mbps
Port Interface	Ethernet (RJ45) Port	5*10/100/1000Tx with 4*PoE, auto negotiation speed, full/half duplex mode, and auto MDI connection
	LED Indicator	Power Ethernet Ports: On – Link / Flash - data transmitting PoE: On – connected to PD devices
	Network Cable	10BaseT: 2-pair UTP/STP Cat.3,4,5 cable EIA/TIA-568 100-oHm (100m) 100BaseTX: 2-pair UTP/STP Cat.5 cable EIA/TIA-568 100-oHm (100m) 1000BaseTX: UTP/STP Cat. 5/5e cable EIA/TIA-568 100-oHm (100m)
	PoE Pin Assignment	RJ-45 port #1~# 4 support IEEE 802.3af End-point, Alternative A mode. Positive (VCC+): RJ-45 pin 2, 4. Negative (VCC-): RJ-45 pin 1, 3. Data (1,2,3,4)
Mechanical Characteristics	Housing	Metal IP30 protection
	Dimension	30 x 95 x 75 mm
	Weight	Unit Weight: 0.77 lbs. Shipping Weight: 0.99 lbs.
	Mounting	DIN-Rail Mounting, wall-mounting (optional)
Power Requirement	Input Voltage	48~55VDC Redundant Input
	Power Connection	1 removable 4-contact terminal block
	Power Consumption	5.5 Watts for system
Environmental Limits	Operating Temperature	Standard: -10°C to 70°C EOT: -40°C to 75°C
	Operating Humidity	5% to 95% (Non-Condensing)
	Storage Temperature	-40°C to 85°C
Regulatory Approvals	EMI / EMS	FCC Part 15 Subpart B Class A, CE EN 55022 Class A, CE EN 55022 Class A, IEC61000-4-2(ESD),IEC61000-4-3(RS), IEC61000-4-4(EFT),IEC61000-4-5(Surge), IEC61000-4-6(CS),IEC61000-4-8(Magnetic Field)
	Stability Testing	IEC60068-2-32(Free Fall), 27(Shock), 6(Vibration)
	Safety	CE, FCC, UL 61010-1, UL 61010-2-201

Table 7.1

Technical Specifications